

# **Mennonites, Hypophosphatasia and Severe Combined Immunodeficiency Disease: The Story of Two Genetic Disorders**

**Cheryl Rockman-Greenberg and Marlis Schroeder,**  
*College of Medicine, University of Manitoba*

## **Introduction**

This series of two articles summarizes the discussion of two conditions in Manitoba Mennonites of which we are very familiar. The Hypophosphatasia (HPP) Story will be discussed by Dr. Cheryl Rockman-Greenberg and the Severe Combined Immunodeficiency Disease (SCID) story will be discussed by Dr. Marlis Schroeder. Many Manitoba Mennonites may be aware of these conditions in their communities and we hope these papers will provide you with some details about the advances in detection and the treatment of these two classes of disorders. We will introduce some of the up-and-coming advances that have the potential of turning often fatal disorders into treatable ones. As well, the message remains that early recognition, treatment and prevention of

many genetic disorders are now possible, with SCID and HPP representing two such examples. The new technologies that have been applied to the study of SCID and HPP will, we hope, lead to better understanding about genetics in general. This new knowledge can be empowering and at the same time can raise concerns about how these tests will be applied in the future. We will begin with a “Genetics Primer,” as both HPP and SCID are genetic disorders, and we will focus on conditions that are the result of “autosomal recessive inheritance.”

### **Genetics Primer**

Every person has approximately 25,000 pairs of genes in each cell of the body. This means there are two copies of every gene in our cells. Our genes carry all the necessary information for normal growth and development and to allow our organs to function normally throughout our lives. This information is found in our genetic code, our DNA. Genetic disorders are often caused by “misprints” in the DNA of one gene. This is called a single gene disorder. Another word for a DNA misprint is a mutation. If both copies of a gene have a mutation, this results in an “autosomal recessive” disorder. An example of an autosomal recessive disorder is cystic fibrosis (CF). Parents of a child with CF are considered carriers of a single gene mutation and the other copy of their CF gene is normal. Carriers usually do not show any signs of an autosomal recessive condition. Only when parents who are carriers of a mutation in the same gene both pass on the gene copy with the CF mutation to their child, the child then has inherited two gene copies with the CF mutation and is affected with this autosomal recessive disorder. See Figure 1 for a diagrammatic representation of autosomal recessive inheritance.

Research has shown that everybody carries approximately two to three autosomal recessive mutations in their genes. This is true also for Mennonite individuals. Many autosomal recessive conditions are described in people of Mennonite descent, including HPP and SCID. The Dutch-North German Mennonite population in Manitoba is quite homogeneous and is known to have descended from a relatively small number of individuals.

This is called a “founding population” and with large family sizes over many generations, combined with some other factors, many autosomal recessive conditions have been recognized in people of Mennonite descent and the responsible genes have now been identified. Other non-Mennonite “founding populations” exist in

Manitoba where certain autosomal recessive conditions are overrepresented but it should be noted that many of these conditions are also found in the general population, albeit less frequently.

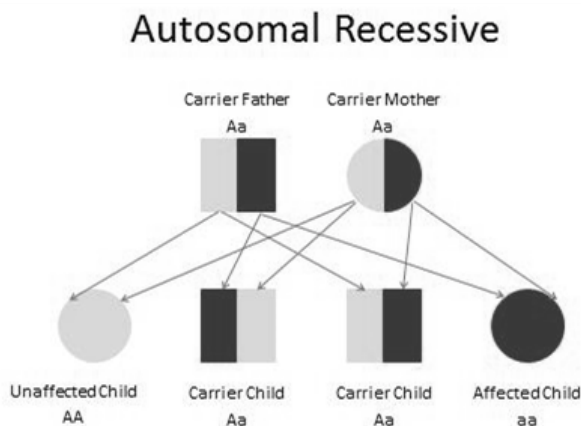

*Figure 1*

## Hypophosphatasia: A Manitoba Story

Hypophosphatasia (HPP) is a single gene disorder affecting the mineralization of the teeth and skeleton. HPP falls into the class of genetic conditions known as Inherited Metabolic Disorders (IMD) also known as inborn errors of metabolism (IEM). IMD are genetically determined disorders that are caused by the abnormalities in a specific enzyme or protein. There are two classes of IMD: one involves a “quantitative” defect in the amount of an enzyme or protein present, and the other is a “qualitative” variation in the properties of a specific enzyme or protein. HPP is a single gene, autosomal recessive, disorder that is one of approximately 7,000 different single gene disorders that have been described to date. Of these 7,000 disorders, the genes responsible for approximately half of these disorders have been identified. Over 550 of these single gene disorders fall into the category of IMD. Individually these conditions are very rare but collectively they are common and they constitute a significant burden of disease for the individual, the family and society. Gene identification and the promise of new

treatments are proceeding at a dramatic pace due to numerous factors. One is advances in science and innovative technology due to close collaboration and networking between basic laboratory scientists, clinician scientists and researchers in many complementary fields including molecular biology, drug development, bioinformatics, epidemiology, health service delivery and genetic counselling. The other equally important factor is the increasing awareness of rare disorders and education and support provided by numerous dedicated family support groups and advocacy networks.

### The Early Days

As I have described, HPP results from “misprints” in the genetic sequence of a single gene. The first report in the English literature of HPP is attributed by many to the world-renowned Dr. Bruce Chown from Manitoba, who in 1935 in the *British Journal of Surgery* described two siblings who in retrospect are felt to have had HPP. The medical literature on HPP truly began to blossom in the 1950s. Dr. J. C. Rathbun from the University of Toronto recognized the association between clinical findings of HPP and low serum level of alkaline phosphatase. Dr. Donald Fraser, also from the University of Toronto, in 1957 classified HPP into three main clinical forms: infantile, childhood and adult. These forms were mostly determined by the age of onset of symptoms and signs.

### Clinical Types of HPP

The disease can be identified right at the time of birth (or in utero on ultrasound) or very soon after birth. This form is known as the perinatal form of HPP, which is the most severe and is usually not compatible with life. Although HPP can be suspected in utero on a routine ultrasound, additional tests are done during pregnancy to confirm the diagnosis as there are many causes of abnormalities in the developing skeleton of a fetus that can be confused with HPP. A baby with the perinatal form of HPP could be stillborn or, until recently, was able to live, sometimes only a few hours or days, succumbing to respiratory failure caused by underdeveloped lungs and a very small chest wall, which are both characteristics of this form of HPP. If HPP does not present in the perinatal period it can also present before the age of six months. This is known as infantile HPP. Babies with infantile HPP may seem normal at birth but gradually there is the onset of poor feed-

ing, failure to thrive, poor body tone, signs of rickets and sometimes seizures. Muscle weakness and delayed motor development are often seen and fractures may occur, which may lead to pneumonia when they involve the ribs and the chest wall. Often patients with infantile HPP manifest seizures and these are specific types of seizures that respond to high dose of vitamin B6. But even though seizures respond to high dose vitamin B6, the prognosis of infantile HPP has been dismal. Babies with infantile HPP, in spite of being a disorder of bony mineralization, sometimes may develop fusion of the skull bones that results in craniosynostosis and neurosurgical procedures to open the bony sutures of the skull are sometimes necessary if there are symptoms and signs (like severe vomiting and headache or changing level of consciousness) of increased intracranial pressure with abnormal appearance of the optic nerves and distinct changes on skull X-ray. Infants with HPP may also suffer from high levels of calcium in the blood and urine. High levels of calcium in the blood can cause malaise and severe vomiting and calcium deposits in the kidney can cause kidney stones. Overall worldwide the onset of HPP in infants less than six months of age has traditionally been associated with mortality between 50-100 per cent.

If the diagnosis does not become apparent at the time of birth or in infancy, symptoms and signs of HPP can still appear after six months of age and this is known as juvenile HPP. Children with juvenile HPP often present with very early loss of their baby teeth, usually well before five years of age, short stature, delayed walking, signs of rickets, fusion of the skull bones and a waddling gait. If the disease does not present in childhood it can also present only in adulthood, typically during middle age where adults can develop recurring fractures, often stress fractures, significant bone pain and ultimately arthritis. Fractures tend to heal poorly and orthopaedic surgery is almost always necessary to try to stabilize them. There is also a clinical form of HPP that is limited to teeth involvement, known as odontoHPP, and a rare form known as benign prenatal HPP.

### **Our Early Research into the Genetic Cause of HPP**

Our research in HPP began in the early 1980s when it was apparent that HPP was more commonly represented in individuals of Mennonite descent (1 in 2,500 Mennonite births vs. 1 in 100,000 in the general population), that the mortality rate in the perinatal and infantile forms was one hundred per cent with children and that

adults with HPP were also suffering greatly from its effects. The cause of HPP was known, meaning that it was known to be a genetic form of rickets/osteomalacia that was characterized by a very low level of serum alkaline phosphatase activity known as the tissue non-specific form of alkaline phosphatase (TNSALP). However, only treatment of the symptoms of HPP, like orthopaedic management of fractures, dental work, physiotherapy, walking aids and pain medications, was available. The classification of HPP was still a clinical one based on age of onset. There was significant variation in the manifestations of HPP between individuals in different families and even between individuals within the same family. The cause of this variability in expression of HPP was not known. We embarked on trying to identify the genetic basis for HPP in our Mennonite population and the reasons for the variable expression seen. This was possible because by 1986 the ALPL gene – the gene that codes for the TNSALP protein – had been identified (“cloned”) and my colleagues and I began a collaboration with a research team at the University of Pennsylvania. Many Mennonite families participated in our research study including the parents of babies with HPP, the first degree relatives and unrelated spouses in these families, as well as children with juvenile or adult HPP and their families. The invaluable contributions of these families to the advances that were to come in HPP treatment cannot be stressed enough and we are very grateful to their willingness and eagerness to participate in our research studies.

The genetic basis for all forms of HPP in Mennonites in Manitoba, as well as in other provinces, was soon identified. One unique mutation (i.e., a genetic change in the ALPL gene encoding TNSALP) was found to be a change in a single letter in the ALPL gene known as the p.Gly334Asp mutation. DNA studies showed that babies who had two copies of the p.Gly334Asp ALPL mutation always had perinatal or infantile HPP, parents of babies with perinatal or infantile HPP were carriers of one copy of the p.Gly334Asp mutation, and that juvenile or adult patients had two different mutations: one the p.Gly334Asp mutation and the other a milder mutation known as the p.Glu191Lys mutation. Thus through our research we were able to understand why some babies had the severest forms of HPP and other children, even in the same family, could have a milder form of HPP. In most cases it depended on the combination of which two DNA mutations were carried by that individual. Because of the results of our genetic studies and other research findings we were able to provide much more accurate genetic counselling to individuals who were themselves at risk for or already had HPP, as well as carrier testing for those who wanted to

learn if they were carriers for either the severe or the mild ALPL mutations. Effective definitive treatment, however, remained elusive, which means there was no effective way to maintain an increase in alkaline phosphatase activity and therefore treatment remained symptomatic, in the sense that we offered orthopaedic management, dental care, physiotherapy, neuro-surgical evaluation as necessary and pain management. To date, over three hundred different “misprints” (mutations) have been described in the ALPL gene in patients with HPP worldwide and all these mutations are recorded in the ALPL Gene Mutations Database maintained by Dr. Etienne Mornet at the University of Versailles in France.

### **From Animal Studies to Human Clinical Trials**

In the 1990s, a mouse strain in which the ALPL gene was “knocked out” opened a whole new era of possibilities for research into this disease. Mice with two “knocked-out” copies of the ALPL gene have bone abnormalities very similar to that seen in human HPP. It was felt that the mouse model of HPP, known as murine HPP, was an excellent model for the human disease. The knockout mice have the same metabolic abnormalities as well as the same skeletal defects as human HPP. Through a clever development of a human recombinant enzyme that made TNSALP, enzyme replacement therapy (ERT) treatment trials began for mouse HPP. The enzyme that was developed consisted of a dimer (two molecules) of TNSALP linked through an immunoglobulin fragment to a tail of ten aspartic acid amino acids. This tail of ten aspartic acid amino acids targeted this molecule to bone, and allowed it to be retained in bone. It was shown through studies in murine HPP that the skeletal abnormalities seen in the knockout mouse could be corrected with ERT with human recombinant bone-targeted alkaline phosphatase. This brings us to December 2007, when a clinical development program for the use of bone targeted human recombinant alkaline phosphatase began to be developed.

### **Clinical Trials**

We were very pleased to be asked to participate in the initial phase one studies and since December 2008 we, with our patients as partners, have participated in many clinical trials of human re-

combinant bone targeted alkaline phosphatase for the treatment of infants, young children, and adults with HPP.

Asfotase alfa is the name of the enzyme that is used in clinical trials for the long term ERT for patients with HPP. The results of the clinical trials to date in infants and children with severe HPP have been dramatic. There has been marked improvement in the skeletal abnormalities of infants and children participating in the clinical trials. These improvements are documented on X-ray and also accompanied by significantly better survival, better lung function, better motor development, improved growth, much less pain and improvement in weakness and in quality of life. The drug, asfotase alfa, is administered subcutaneously, much like an insulin injection, three times a week. Side effects of the medication have been quite minimal. The main side effect has been local skin reactions including redness and some atrophy of the skin at injection sites. The best way to minimize the side effects of injection site reactions is to pay meticulous attention to the rotation of injection sites. Although antibodies to asfotase alfa are detected in the blood of the patients participating in the clinical trials, antibody levels are very low and there has been no evidence of any resistance to the treatment or any severe allergic reactions.

In September 2015 Health Canada issued a Notice of Compliance with Conditions (NOCC) and has approved asfotase alfa (STRENSIQ™) (Alexion Pharma) for enzyme replacement therapy in patients with a confirmed diagnosis of pediatric-onset HPP. This is an incredibly exciting advance. Asfotase alfa is a Canadian discovered enzyme and was developed to meet the needs of HPP patients in Canada and throughout the world. Patients in the clinical trials currently remain on treatment and the next phase is to progress to the development of a long term sustainable reimbursement strategy in Canada for this very exciting drug. As well, there will be the transition of study patients with paediatric-onset HPP from clinical trial drug to commercial product and the development of clinical practice guidelines for the treatment of these and other patients in Canada with confirmed paediatric-onset HPP. An international HPP Registry sponsored by Alexion has also been started. Much more research also needs to be done on adult-onset HPP and this is in progress. The organization Soft Bones Canada ([softbonescanada.ca](http://softbonescanada.ca)) has recently been formed and represents a dedicated group of individuals closely connected to HPP whose aims are to increase awareness about HPP, to provide information and support to patients and their families living with HPP and to educate, empower and connect HPP families across the age spectrum. The Scientific Advisory Board reporting to the



Board of Directors of Soft Bones Canada has been created and an inaugural family conference for HPP has been planned by Soft Bones Canada and the Scientific Advisory Committee for July 22-23, 2016 in Winnipeg.

### Acknowledgements

Sincere thanks to Enobia Pharma (former Montreal-based company) and to Alexion Global (Headquarters Cheshire, CT) for all clinical trial activity, to the University of Manitoba, to the Winnipeg Regional Health Authority/ Health Sciences Centre, to our dedicated research team at the Children's Hospital Research Institute of Manitoba, to our many community-based partners including CORD, Ronald McDonald House and Soft Bones Canada, and especially to all the patients and their families.

### References

- Fraser, D. (1957). Hypophosphatasia. *American Journal of Medicine*, 22, 730-746.
- Greenberg, C. R. (2013). Hypophosphatasia. *Pediatric Endocrinology Reviews*, 10(Suppl2), 40-48.
- Leung, E., Mhanni, A., Reed, M., et al. (2013). Outcome of Perinatal Hypophosphatasia in Manitoba Mennonites: A Retrospective Cohort Analysis. *Journal of Inherited Metabolic Disease Rep.*; 11(Apr 12), 73-78.
- Mornet, E. The Tissue Nonspecific Alkaline Phosphatase Gene Mutations Database. [http://www.sesep.uvsq.fr/03\\_hypo\\_mutations.php](http://www.sesep.uvsq.fr/03_hypo_mutations.php).
- Whyte, M. P., Rockman-Greenberg, C., Ozono, K., et al. (2016). Asfotase Alfa Treatment Improves Survival for Perinatal and Infantile Hypophosphatasia. *Journal of Clinical Endocrinology Metabolism*, 101(1), 334-342.
- Whyte, M. P., Greenberg, C. R., Salman, N. J., et al. (2012). Enzyme-Replacement Therapy in Life-Threatening Hypophosphatasia. *New England Journal of Medicine*, 366(10, Mar 8), 904-13.

## **Mennonite Infants and Severe Combined Immunodeficiency Disease: A Translational Research Report**

Primary Immunodeficiency diseases (PID) include a large number of syndromes, of which Severe Combined Immunodeficiency Disease (SCID) is the most severe. SCID results from

defects in genes that control the development of the immune system.

Affected infants normally present at less than six months of age with a variety of symptoms including chronic recurrent thrush, chronic diarrhea, failure to thrive, recurrent infections and recurrent pneumonia, viral or bacterial. The only treatment is a stem cell transplant without which these infants die usually before the age of one year (Dvorak, et al., 2013).

An understanding of basic immunology is required to comprehend the mechanism of this disease and thus the clinical picture. The problem lies within the lymphocytes which, depending on the type of SCID, are either not present or have a functional defect that prevent them from being activated to function normally.

Lymphocytes can be divided into three broad categories: T, B and NK (natural killer) cells. Defects in the development of any of these three subsets can lead to a PID. However, in SCID, T cells are either absent or are functionally abnormal, resulting in the classical clinical picture.

A basic classification of SCID is outlined in Figure 2. The variants commonly seen in Mennonites are underlined.

The hallmark is the absence of T cells. However, in one of the types seen in Mennonites, T cells are present but do not function normally (Notarangelo, 2013). Although the basic laboratory tests may not identify these infants, they clinically are SCID babies and require the same intensive therapies as the more classic forms.

## CLASSIFICATION OF SCID

- T<sup>-</sup> B<sup>+</sup> NK<sup>+</sup>
  - Common gamma chain; JAK3 defect
- T<sup>-</sup> B<sup>-</sup> NK<sup>+</sup>
  - RAG1, RAG2 – Omenn's syndrome
- T<sup>-</sup> B<sup>+</sup> NK<sup>+</sup>
  - CD3δ defect
  - Di George Syndrome (del22q11.2)
- T<sup>-</sup> B<sup>-</sup> NK<sup>-</sup>
  - ADA
- T<sup>+</sup> B<sup>+</sup> NK<sup>+</sup>
  - Mennonites – ZAP70
  - First Nations - IKBKB

Figure 2

SCID can be divided into two major groups according to their clinical and laboratory picture. The 'classic' or 'typical' SCID presents with a low or absent lymphocyte count ( $<3 \times 10^9$  cells/ $\mu$ l),  $<10\%$  response to PHA, and a defect in a known SCID gene.

The second group, 'leaky SCID' comprises a wide variety of different types with different mutations, but has a similar clinical picture. The lymphocyte count ranges between 3 and  $1.5 \times 10^9$  cells/ $\mu$ l with a decreased response to PHA, and a variable defect in one of the SCID genes. The Mennonite ZAP70 variant is included in this category.

### Mennonites in Manitoba

The Dutch/German Mennonites in Manitoba are primarily immigrants from Russia. There were two distinct migrations. The first migration was in the 1870s with the arrival of over 7,000 individuals who settled initially in the former Mennonite East Reserve, around today's Steinbach area. Within a short period, some of these families moved west, to the former Mennonite West Reserve, around what is now the Altona/Morden/Winkler area. In the 1920s and thereafter, a further migration ensued within this group, primarily to Mexico and Paraguay, but also to other countries in Central America and South America.

The second major migration of over 20,000 Mennonites from the Soviet Union occurred between 1922 and 1930, after the Bolshevik revolution in Russia and World War I. In contrast with the first migration in the 1870s, these individuals settled not only in rural locations but also in urban areas in southern Manitoba. (Orton, et al., 2008).

The SCID babies to date have all been descendants of the first migration. This includes babies from Mexico who were diagnosed and treated here. The type of SCID seen in these babies varies with church affiliation. Although not exclusive, the ZAP70 mutation is seen in families who are or were affiliated with the Church of God in Christ, Mennonite (Holdeman). The other mutations are seen primarily in families from the *Kleine Gemeinde* (now known as the Evangelical Mennonite Conference), Bergthaler and Old Colony congregations. These are tight-knit communities, some of which have no or limited intermarriage from outside, although this is gradually changing with increasing urbanization.

## **Inheritance Pattern**

SCID is commonly seen in genetic isolates, such as the Mennonites. It is inherited most frequently as an autosomal recessive as shown in Figure 1. There is a 1 in 4 chance of an infant being affected in each pregnancy. The risk is the same for each pregnancy.

## **Clinical Picture**

At birth, the infants are entirely normal – no skin rash, no congenital abnormalities, and no stigmata that could suggest an underlying problem. Blood work, including a lymphocyte count, is not routinely done. However, if it is, physicians may not notice the absence of lymphocytes. On the other hand, in the case of ZAP70 deficient babies, the lymphocyte count is normal. A diagnosis at birth is therefore rare.

Babies are often breast fed so that their clinical presentation may be delayed because of a protective effect, initially from maternal antibodies that have crossed the placenta and later from antibodies in breast milk. Babies are therefore rarely diagnosed before the age of three months when the maternal antibodies have essentially disappeared.

The initial symptoms may include oral thrush, difficulty feeding, diarrhea and irritability. Since these are not uncommon complaints in infants, they may be ignored or minimized by the health care worker. This may be followed by evidence of an upper respiratory tract infection, rapid breathing. Although these symptoms may bring the baby to the physician, the diagnosis may not be considered because of the rarity of the condition. Gradually the symptoms worsen with the baby often being admitted to an intensive care unit, requiring supportive ventilation.

A careful family history is most important. Questions such as consanguinity, death in infancy of a relative (uncle, aunt, cousin) need to be asked. Often this information is not readily available and the parent(s) will have to ask their parents/grandparents to help complete the picture.

A sample pedigree is shown in Figure 3 which shows the interrelationship of three affected individuals. Affected infants are depicted as solid symbols while carriers are shown as half-shaded circles and squares. They all descend from a common ancestor born in 1816. Similar consanguinity in other affected individuals from other families (not shown) is also seen.

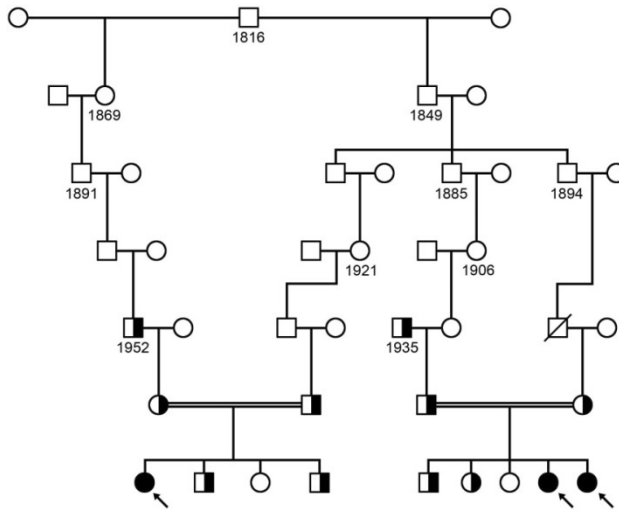

Figure 3

A knowledge of church affiliation may also direct the physician towards the SCID variant, as ZAP70 is more commonly associated with the Holdeman community while the ADA and CD3 $\delta$  mutations are associated with the Bergthaler and Old Colony Mennonites.

The physical examination is usually unremarkable except for the signs associated with the infection and/or failure to thrive that brought the baby to medical attention. These may include oral thrush, a skin rash, respiratory findings, the absence of lymph nodes and tonsils.

### Laboratory Picture

Basic laboratory tests performed in the evaluation of a baby with a possible diagnosis of SCID include: a lymphocyte count, subset analysis, immunoglobulins and in vitro stimulation of cells with phytohaemagglutinin (PHA).

Again the results vary with the type of SCID. In the 'classic' SCID, the diagnosis is more evident because of the low or absent lymphocytes and the low immunoglobulins. In the 'leaky' SCID variants, lymphocytes may be present as may be immunoglobulins, which, however, are non-functional.

The subset analysis helps to identify the type of SCID. The 'classic' SCID either has no or very low CD3, a T cell marker, cells. The ZAP70 variant, however, may have normal or even high CD3

cells but low or absent CD8 cells, a T cell subset, a hallmark of this type of SCID.

Finally, the cells do not respond in vitro to phytohaemagglutinin (PHA), a pan-T cell stimulant. This is true in 'classic' SCID and in most of the SCID variants.

### **Management**

The treatment of choice is a hematopoietic stem cell transplant (HCT). If a new, functioning immune system is introduced, the children can live a normal life. The results of transplant are related to the time of diagnosis and the absence of infection at the time of HCT. With transplant, in the absence of infection, the long term survival is over ninety-five per cent (Pai, et al., 2014). Early diagnosis and treatment of infections are essential for a good outcome and long term survival.

The preferred donor is a sibling or rarely a parent who is identical for the transplantation markers (HLA). Alternate donors include a mismatched parent or relative, a matched or minor mismatched unrelated donor or cord blood. Chemotherapy may have to be given in the non-identical setting, depending again on the type of SCID.

An alternate form of therapy is gene therapy. This experimental treatment is presently being undertaken in infants with ADA deficiency and X-linked SCID. Preliminary results are encouraging, however, much more remains to be done before gene therapy becomes the treatment of choice. Enzyme replacement in ADA deficient individuals is an option; however, this treatment is life long and is associated with a variety of complications including incomplete immune reconstitution and development of an antibody to the enzyme. At present, HCT remains the treatment of choice for the majority of SCID patients.

### **Newborn screening**

Newborn screening has become a standard in the early diagnosis of primarily metabolic diseases. The role for screening is constantly expanding, with the inclusion of cystic fibrosis as an example. There are more than thirty diseases for which newborns are routinely tested in Manitoba today.

More recently, screening for SCID has become an important tool for the early diagnosis of this disorder (Kwan & Puck, 2015).

Many states in the United States are also screening for this disorder, as are two provinces in Canada. The test is an assay for TRECs (T cell receptor excision circles) which are absent or significantly decreased in most types of SCID, specifically those that have no or low T cell numbers. TREC numbers are an indicator of thymic production of T cells, their absence or low numbers indicating an abnormality in T cell production or an abnormal loss of T cells. Any infant who is identified as having low TRECs is investigated further in order to ascertain the cause.

A major problem in Manitoba is that we have two types of SCID, ZAP70 and IKBKB, in which T cells are present. These infants have TRECs and will not be identified by the screening test that is presently being used elsewhere. If only the TRECs assay were used, we would miss about half of the SCID babies in the province. Investigations are proceeding to develop an additional test that would hopefully identify most, if not all, SCID babies in this province. It is hoped that implementation could begin by 2017, as early diagnosis and treatment are crucial for a good outcome (Pai, et al., 2014).

### **New challenges**

Although the affected babies are clinically cured, we do not have adequate long-term follow up to answer many questions, including:

1. Are the grafts permanent or may they be lost?
2. Is there an increased risk of malignancy?
3. Is there an increased risk of auto-immune diseases such as rheumatoid arthritis, systemic lupus erythematosus, or coeliac disease?

With our improved knowledge and understanding of these diseases and their successful treatment, we have now introduced a new variable: a possible new ethical dilemma. We have now 'cured' patients who in the future will be in the child bearing age. How do we counsel them at that stage? If the partner does not carry the mutant gene, all the offspring will be carriers, but unaffected. If, however, the partner is a carrier, then each infant has a one in two chance of being affected. Families are routinely offered genetic counselling and carrier testing, both of which become crucial in these families and are available on a voluntary basis.

We have come a long way, from no knowledge of the disease and the acceptance of infant mortality as “God’s will,” to an understanding of SCID – the genetics, the clinical picture and the successful treatment. Early diagnosis is requisite for a good outcome post-HCT. Survival is excellent if the HCT is performed before the age of three and a half months. It is approximately ninety-five per cent in an uninfected infant, compared to fifty per cent in a baby with an active infection. On the other hand, if the infection is successfully treated and the infant has a transplant even at an older age, the outcome is still over eighty per cent (Pai, et al., 2014). Newborn screening is therefore essential for early diagnosis so that the HCT can be done before the baby becomes infected. Newborn screening is universal and does not target any specific community, making it widely acceptable.

Through the cooperation of families with an affected infant, we have been able to determine the cause and the mechanism of many types of SCID, including those seen in the Mennonites.

### Acknowledgments

Special thanks to all the patients and their families and to Dr. Teresa Zelinski, University of Manitoba.

### References

- Dvorak, C. C., Cowan, M. J., Logan, B. R., et al. (2013). The Natural History of Children with Severe Combined Immunodeficiency: Baseline Features of the First Fifty Patients of the Primary Immune Disease Consortium Prospective Study 6901. *Journal of Clinical Immunology*, 33, 1156-1164.
- Kwan, A., Puck, J. M. (2015). History and Current Status of Newborn Screening for Severe Combined Immunodeficiency. *Seminars in Perinatology*, 39, 194-205.
- Notarangelo, L. D. Functional T Cell Immunodeficiencies (with T Cells Present). (2013). *Annual Review of Immunology*, 31, 195-225.
- Orton, N. C., Innes, A. M., Chudley, A. E., & Bech-Hansen, N. T. (2008). Unique Disease Heritage of the Dutch-German Mennonite Population. *American Journal of Medical Genetics Part A*, 146, 1072-87.
- Pai, S. Y., Logan, B. R., Griffith, L. M., et al. (2014). Transplantation Outcomes for Severe Combined Immunodeficiency 2000-2009. *New England Journal of Medicine*, 371, 434-446.